



## Processors & Mix Tanks

Serving the food, dairy, & beverage industry with strong, long-lasting equipment at competitive prices.



[www.ancoequipment.com](http://www.ancoequipment.com)

# Processors and Mix Tanks

Anco processors are designed to heat and cool a variety of dairy, beverage, food, and many other fluid processing applications.

Anco offers Single Shell tanks as an option when heating or cooling is not necessary.

Each tank's size, dimensions, cover, bottom design, and agitator are customized to the client's application.

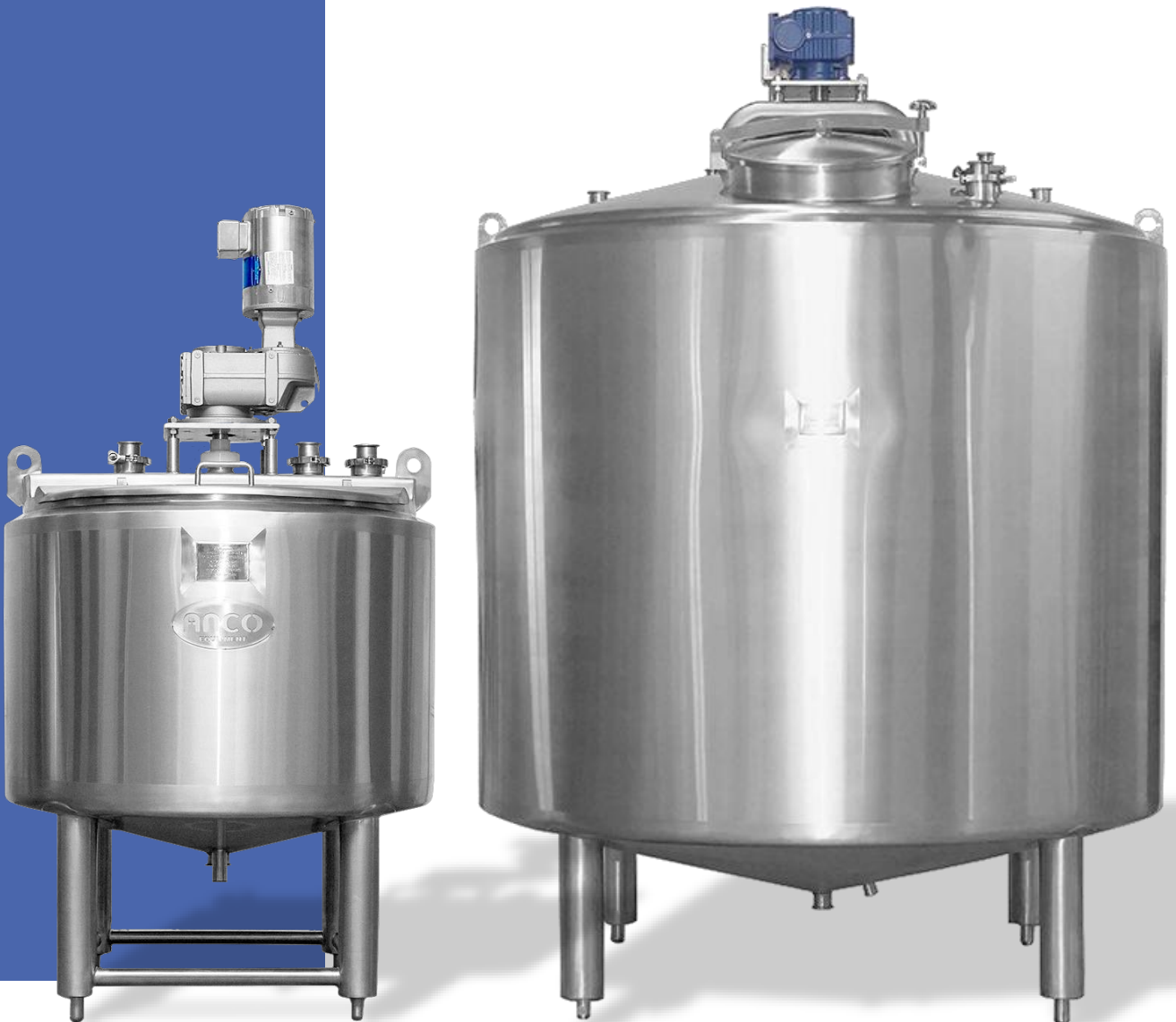

# Standard Features: Jacketed Process Tank

- Food Grade Euro-drive Gearbox
- Wash-down motor and all Stainless Motor options
- Interior wall 11 Gauge 304ss, #4 finish (316 option)
- Stainless steel dimple plated jacket
- Exterior wall 14 Gauge 304 Stainless Steel, No. 4 finish
- 1-4 Heating Zones
- 17 to 20" Manway or Wing Doors
- Tank Vent on Dome Top
- Bottom sweep agitation, Side and Bottom Scrape, Full Sweep or no Agitation
- Baffle(s)
- 2 Stainless Steel CIP Spray Balls Standard (customization available)
- 1.5" FNPT Standard Jacket Ports (customization upon request)
- 1.5" to 6" Tri Clamp Ferrule options
- Thermowell(s) for product temperature testing
- Adjustable Ball Feet or Heavy- Duty Casters





# Tank Bottom Designs

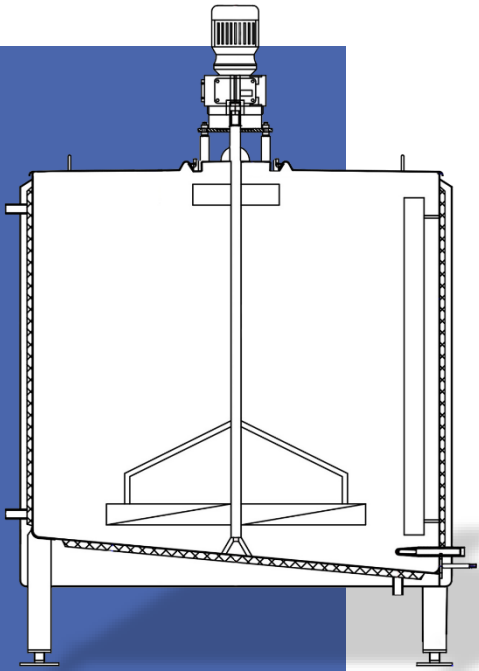

Slope Bottom Design

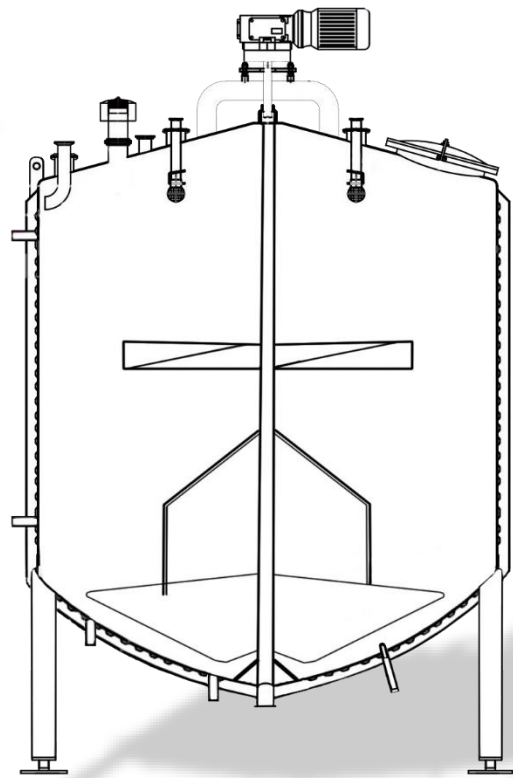

Dish Bottom Design

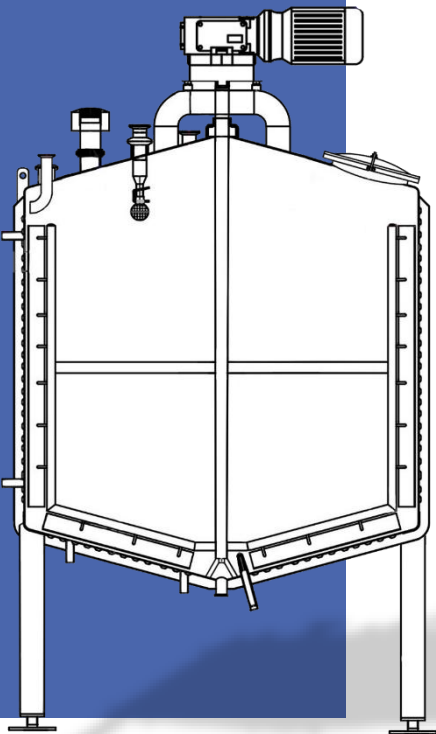

Cone Bottom Design

# Processor Lid Options



Dome Top with Manway  
Available: 200-3,000 Gallon



Wing Top with Center Bridge  
Available: 35-2,000 Gallon

# Agitation Options

Anco offers a variety of agitator design options for different product applications.

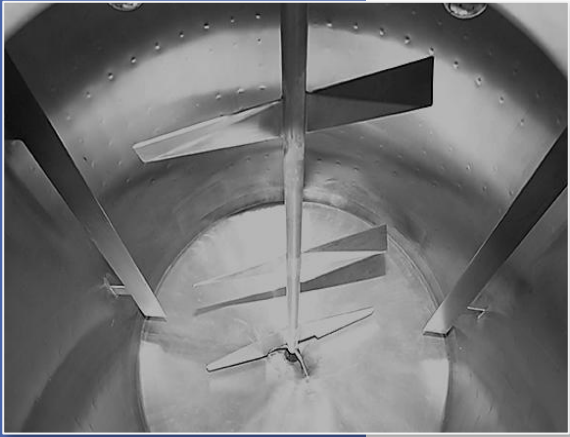

Standard Blade Agitation

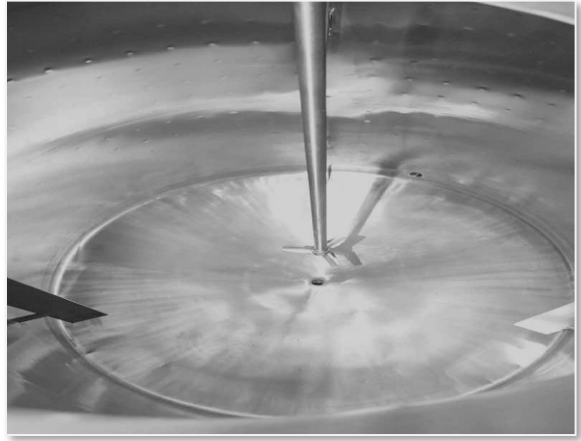

High Speed Agitation

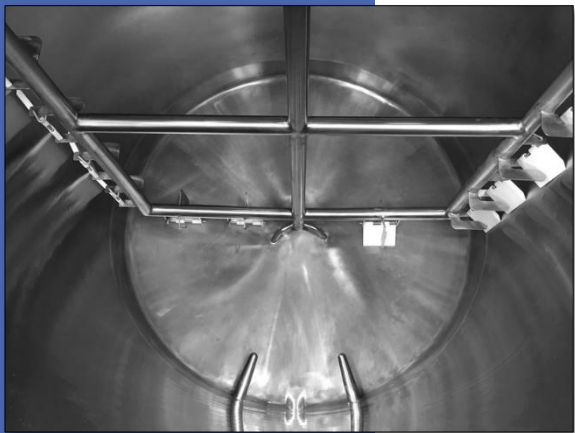

Side Scrape Agitation

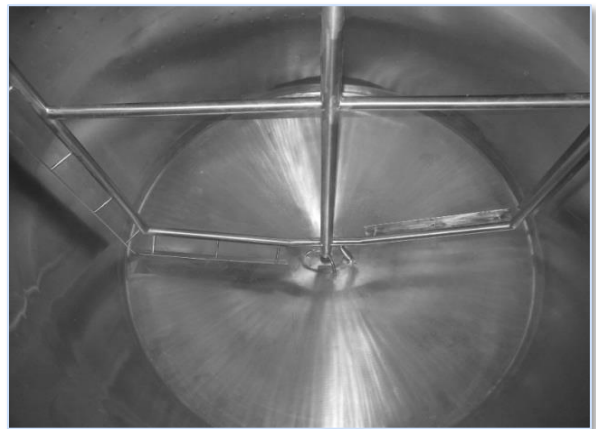

Full Sweep Agitation



## Contact us:

**Email:** [info@ancoequipment.com](mailto:info@ancoequipment.com)

**Phone:** (920) 569-3530

**Mailing Address:**

1070 East Glenbrook Drive, Suite #2

Pulaski, Wisconsin 54162

[www.ancoequipment.com](http://www.ancoequipment.com)