

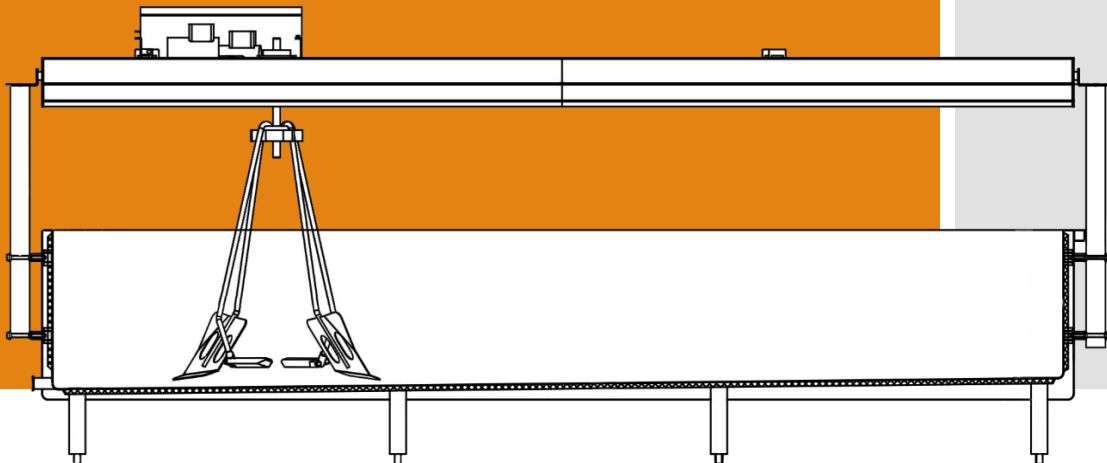

Cheese Vats

Serving the food, dairy, & beverage industry with strong, long-lasting equipment at competitive prices.

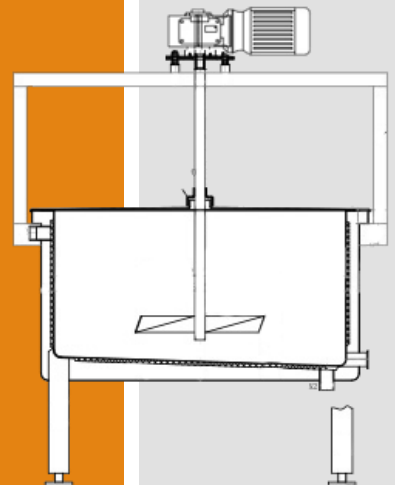
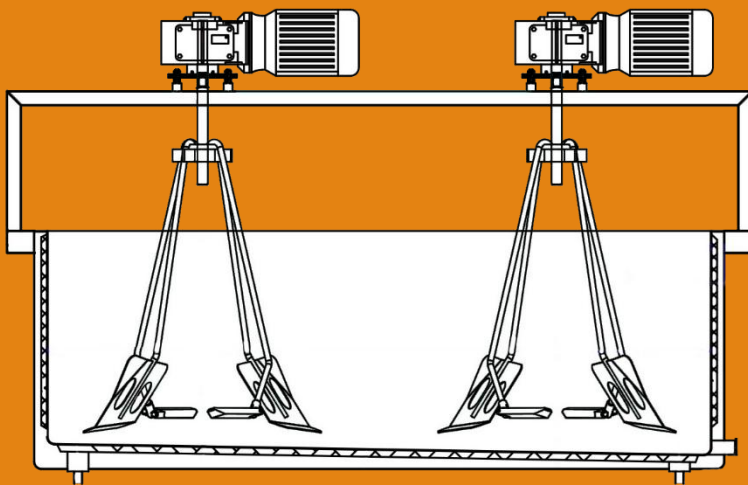

Open Cheese Vats

Cheese Vats are essential to the cheese making process. They are typically the next stage after the milk has been pasteurized. Anco's vats are easy to install, easy to maintain, and easy to use. We can customize the vats gallon size, dimensions, and features to fit your application and facility perfectly.

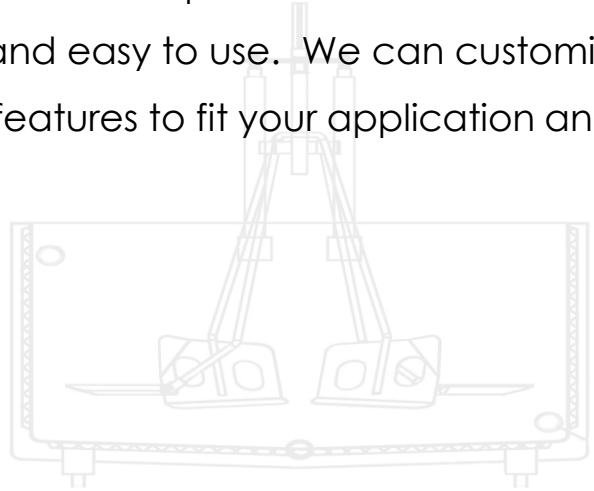

Open Cheese Vats

Anco Open Cheese Vats are used to turn your raw or pasteurized milk into cheese. These vats are constructed with 304 Stainless Steel and have an amazing food-grade No. 4 finish. Custom tank widths and heights available at no extra charge. Easy to use and install. Vats have a dimple plate jacket for effective heating and cooling and can be used with steam or a hot water boiler system. Cool your product by using tap water, chilled water reserve tank an ice builder or plate chiller.

Standard Features:

- Vat sizes available: 100-2,500 gallons
- One set of Paddles
- One set of Forks
- Adjustable Ball Fee
- Tri-Clamp Butterfly Valve
- Stationary & Traveling Agitation
- Nema 4 VSD or PLC Touch Screen Controller



Pasteurizing Cheese Vat

The removable top option is popular with our pasteurizing cheese vat. It can only be used in tank sizes from 50-300 gallons. The cover is a split top and the agitator is completely removable. This is designed to make cheese in the vat after pasteurization.

Standard Features:

Vat sizes available: 50-300 gallons

SEW Euro-drive motor

Removable Agitation

Adjustable Ball Feet

2" Valve Outlet

Multiple Ports

(2) CIP Spray Balls

Accessories:

Anderson Chart Recorder

Product & Airspace Thermometers

Electric Airspace Heater & Controller

Leak Detection Valve

Whey Screen

Curd Knives/Harp

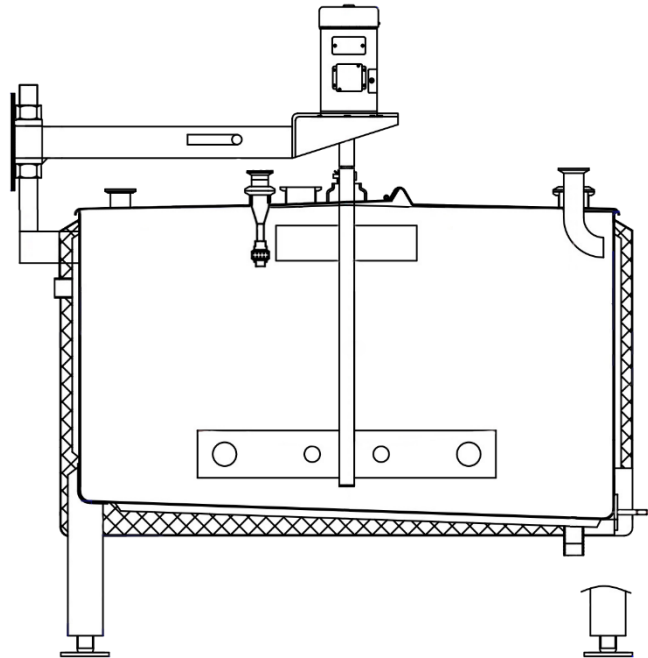

Cheese Vat Accessories

Accessories:

- 1) Cheddaring/Curd Mill
- 2) Vat Whey Strainer
- 3) Curd Knives
- 4) 20 & 40 LB Block Cheese Forms
- 5) Whey Strainer Pail
- 6) Curd Pail

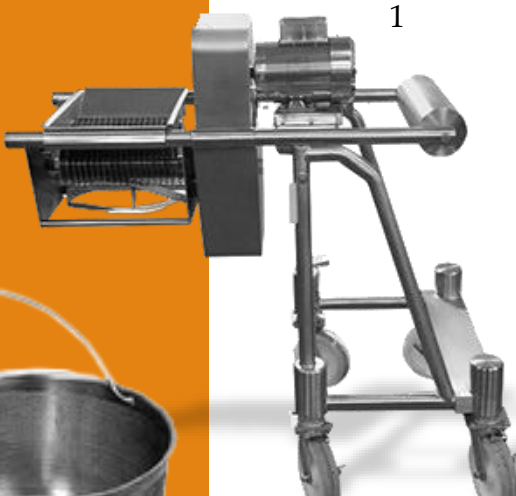



Contact us !

Email: info@ancoequipment.com

Phone: (920) 569-3530

Mailing Address:

1070 East Glenbrook Drive, Suite #2

Pulaski, Wisconsin 54162

www.ancoequipment.com